

Ancillary Equipment

Floor Mounted Door Retainer

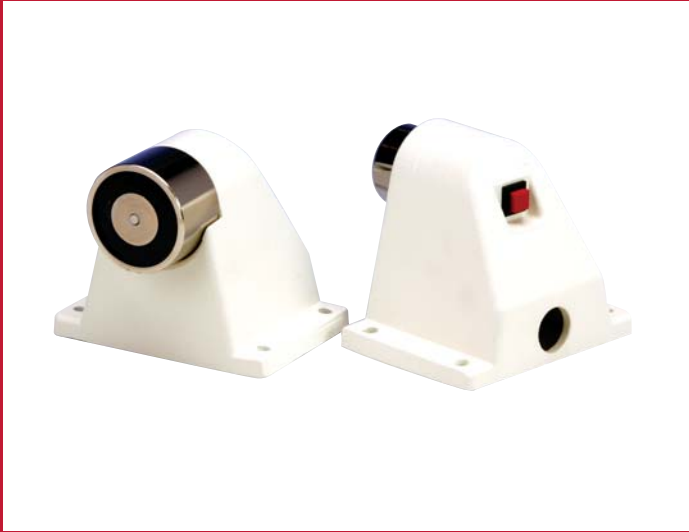

Features

- 200N or 500N holding force
- Zero residual force
- Robust aluminium construction
- surface cable entry
- Manual release switch
- Supplied with keeper plate

Overview

Floor mounted door holders are designed to provide convenient access by holding doors open and releasing them when an alarm is triggered.

The unique design provides maximum protection for areas subject to vandalism or accidental damage. It is comprised of rugged cast aluminium, a holding magnet with integral ejection pin and a manual release switch.

Cable entry can be through the base or through a 20mm hole provided for surface mounted conduit or pyro.

- Fire
- Railway/Marine
- Security
- Hazardous Area
- Industrial
- Public Warning

Applications

- Hospitals, Offices, Hotels and Nursing Homes

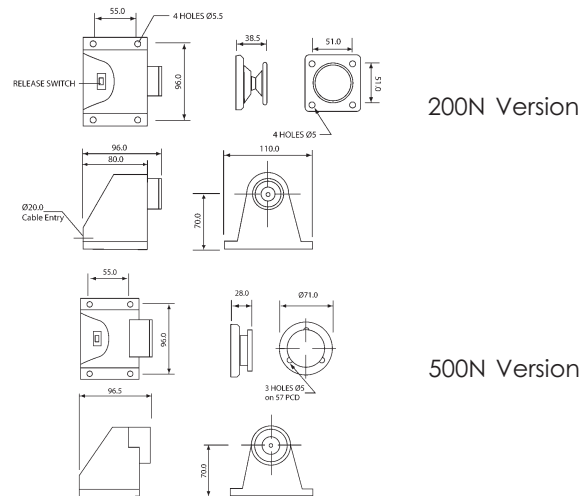

Part No.	Colours	Holding Force	Residual Holding Force	Voltage	Current
17-970372	White	200N	Zero	24V DC	45mA
17-970373	White	500N	Zero	24V DC	90mA
Accessories					
17-970380	Adjustable 200N Keeper Plate				
17-970381	Floor Mounted Bracket				
17-970382	Chain Keeper c/w chain				
17-970383	Chain Keeper c/w chain & O Ring				

IP Rating: Indoor **Rating:** N/A **Frequency:** N/A **Construction:** White painted housing, zinc plated magnet
Cable Entries: 1 **Weight:** 700g (200N variant) & 1000g (500N variant) **Compliance:** EN54-11