

Sounders

Nexus Sounder (AC)



Features

- 105dB, 110dB and 120dB sound output variants
- Quarter turn fasteners for ease of installation
- First-fix, wire to base technology
- IP66 rated
- Volume control for greater flexibility - 20dB
- Three alarm stages (110dB & 120dB variants)

Overview

The Nexus sounder is designed for industrial, fire and marine use.

Connections are made to the base during the initial wiring phase which results in faster and more reliable installation. In addition, the head "clicks into place" and is fixed by quarter turn fasteners avoiding the need to screw up four individual screws thus enabling faster installation and accurate seal compression for weatherproofing.

IP66 as standard means that Nexus can be installed in almost any location.

Applications

- Fire alarm; conveyors; process control alarm; cranes; moving machinery; general signalling; marine

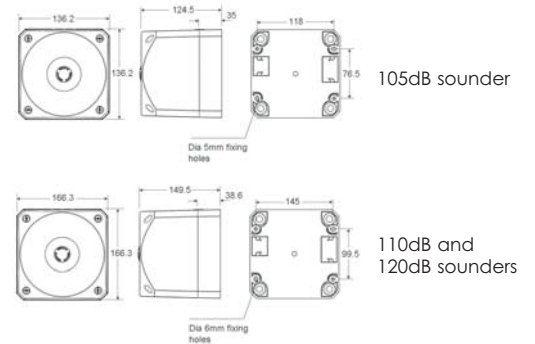

- Fire
- Security
- Industrial
- Railway/Marine
- Hazardous Area
- Public Warning

Part No.	Colours	Audibility at 1m (tone dependent)	Tones	Voltage	Current
18-980548	Red	105dB (A)	64	110/230V AC	40mA (max)
18-980557	Red	110dB (A)	64	110/230V AC	40mA (max)
18-980605	Red	110dB (A)	64	24-48V AC	10-50mA
18-980551	Red	120dB (A)	64	110/230V AC	200mA (max)

IP Rating: IP66 Rating: Continuous Frequency: See Tone Table Operating Temp: -25°C to +55°C
 Cable Entries: 5 Weight: 105dB Sounder - 0.7kg; 110dB Sounder - 1.1Kg; 120dB Sounder - 1.8Kg