

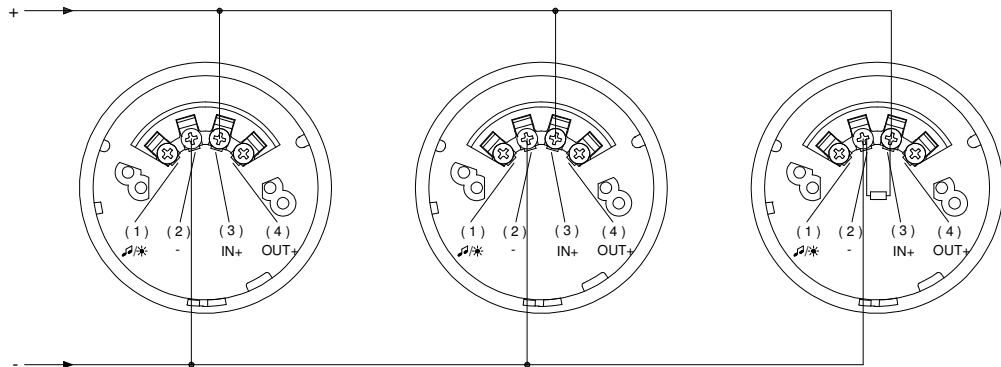

Sonos Fire Alarm Wiring Diagrams

1. Basic circuit without head removal detection



Note: When using this configuration it is recommended that the head is locked onto the base.

2. Circuit with head removal detection

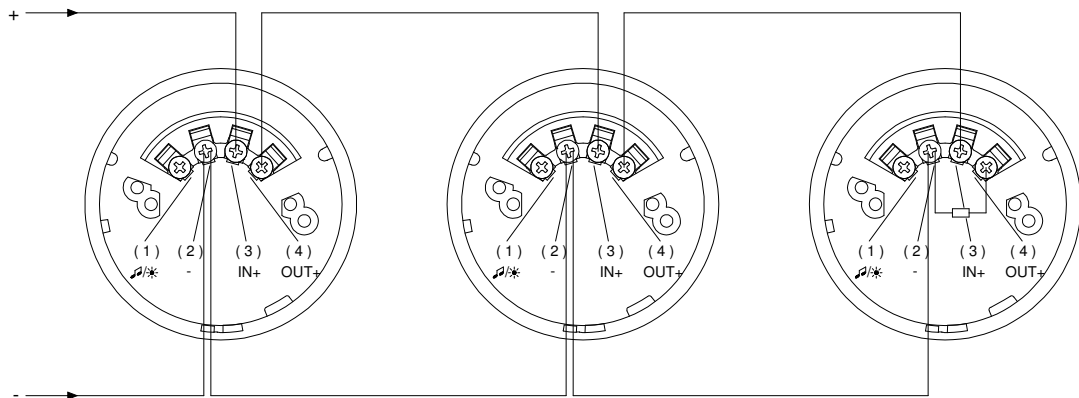

Removal of a sounder head in this configuration will result in an open-circuit fault.

NOTE: sounders downstream of the missing device will not sound in the event of an alarm.

3. Circuit with head removal detection and diode

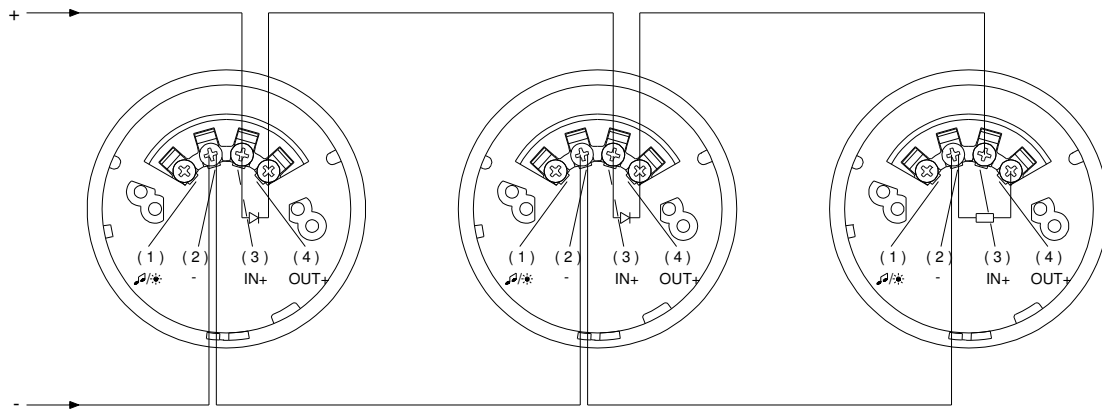

Fitting a diode in the base as shown above ensures that removing a sounder head results in an open circuit fault whilst enabling the downstream devices to continue operating in the event of an alarm.

Note: The diode must be rated for at least the full load current of the sounder circuit.

4. General Information

a) Sounder-Beacon Models

When using sounder-beacons connect both terminals 1 and 2 to the negative supply for simultaneous operation of the sounder and beacon.

Alternatively, the beacon can be controlled independently of the sounder using a 3rd wire and a switched negative signal to terminal 1.

Special variants with terminals 1 and 2 permanently connected in the sounder-beacon head are available on request. Contact Klaxon for more information.

b) Beacon-only Models

Beacon-only models are wired as per the diagrams above, but with the negative supply connected to terminal 1 rather than terminal 2.

c) Installation Guide

The wiring diagrams should be used in conjunction with the installation guide supplied with the products. The installation guide provides full details of the product specification, installation and controls.